

IMSE UltraBase20

Quick start guide

Welcome to Ultra!

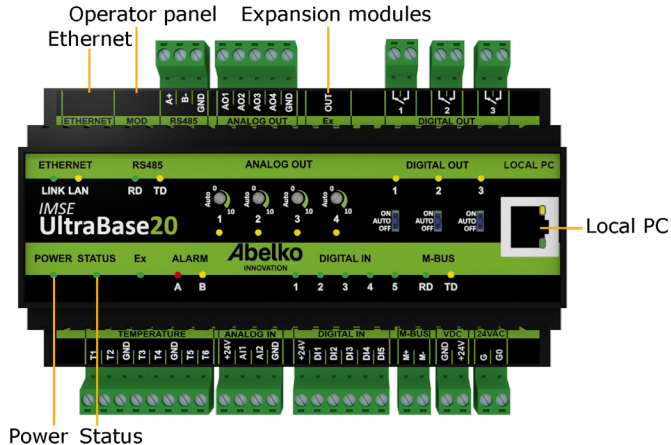

All users of this product must carefully read the manual and take necessary safety precautions.

Safety instructions

If the product is not used as intended its protection and safety functions may not work.

Installation

The unit is to be mounted on a DIN rail in a locked cabinet. Installation is carried out by a qualified electrician. Cables must be fastened and secured so that no risk for injury or fire exists. Ventilation openings in the device housing may not be covered.

A circuit breaker shall be installed close to the unit and its power supply. Function and position shall be clearly labelled. This must also be done for dangerous voltages connected to built in relays. External voltage source connected to **DIGITAL OUT** must be limited to a maximum of 2 A.

The equipment must be unplugged from the mains and other possibly dangerous voltage sources during installation and service.

Power supply

UltraBase20 can be powered i serveral ways. Requirements and characteristics of the unit's inputs and outputs can be found in the table below.

Port	Supply	Supply expansion module (port Ex)
VDC	24 VDC* (>300 mA)	24 VDC, 1A
24VAC	24 VAC (>300 mA)	No
	24 VDC* (>300 mA)	No

* Stabilized DC voltage.

The **Power** LED lights up when the device is energized and the **Status** LED lights up when the device has started up and is working.

Safety instructions



All external equipment connected to the device must have double or enhanced isolation (class II) from power mains or other dangerous voltage source (>50 VAC or > 75 VDC).



Note that all cables used must be approved for at least 50 °C ambienttemperature.



At high ambient temperatures there is a risk for burning injuries. Wait for the equipment to cool down, and use protective gloves.

Network connection

The unit is connected to a permanent network by the **Ethernet** port. The factory default IP address is **10.0.48.94**.

Local PC is used only to connect the unit directly to a PC. It has IP-address **192.168.142.1**, and can be used to configure the regular network connection in the UltraBase20.

When you use the **Local PC** port, the computer should be configured for **DHCP** (which it usually is).

1. Open a web browser and enter the IP address <https://192.168.142.1> in the address bar. This will take you to the login page.

User name and password the first time you log in:

User name: **config**

Password: **ef56**

2. Go to the menu **Communication** and **Network**, and set the **IP address** and **netmask**, in order to configure the settings for the port marked **Ethernet**. You can also check the **DHCP** box, the unit will then

automatically get network settings. After a while, you can see which IP address it received. You can use this IP address to access the device from a PC, connected to the same network.

HTTPS

The first time you log in to an Ultra, you will be warned that the connection is not secure, or similar. This is because the HTTPS protocol ensures a secure and encrypted connection. The security is guaranteed by a certificate, which needs to be issued for a specific IP number. Since the IP address is and needs to be configurable, there is no signed certificate for the unit.

You need to accept and add this exception. The procedure differs depending on which browser you are currently using. The communication is still encrypted, so no-one can see, for example, which passwords are being used.

Graphical programming

Graphical programming is available as an installable program. Download it at www.abelko.se

There is also a link to the program in your units user interface under **Configuration** and **Graphical programming**.

Analog outputs

There are four analog outputs for 0-10 V, marked **AO**. The figure below is an example on how you can connect an AC-powered valve controller.

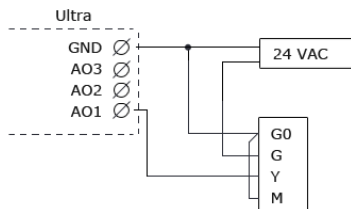

Digital outputs

There are three digital outputs, marked **DIGITAL OUT**. They are normally open relays with breaking capacity of 250 VAC/2A or 30 VDC/2A with resistive load.

Temperature sensor inputs

There are six inputs for resistive temperature sensors, marked with **T**. They have a measurement range of 800 to 1600 Ohms and works for example with PT1000 sensors (approximately -50°C to 150°C) and Ni1000 sensors.

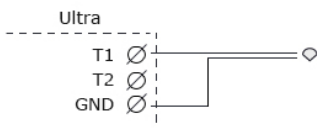

Analog inputs

There are two analog inputs, marked **AI**. These can be configured to measure 0-10 V or 0-20 mA.

Digital inputs

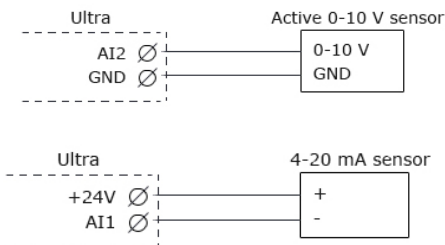

There are five digital inputs, marked **DI**. These can be used for digital status, counters and frequency measurement.

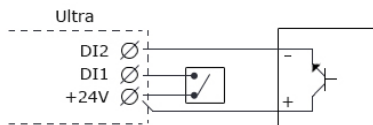

Cleaning

The housing is cleaned from dust and dirt using a dry cloth. Do not use chemicals.

Recycling

When recycling, sort UltraBase20 as electronics.

Repair and service

Reparation and service shall always be performed by Abelko Innovation. Contact your distributor first if the need arises.

Manuals, updates och other information are available at
www.abelko.se.